

SUPERFICIE ESENTE DA AMMACCATURE, GRAFFI E MACCHIE

A

B

C

D

E

F

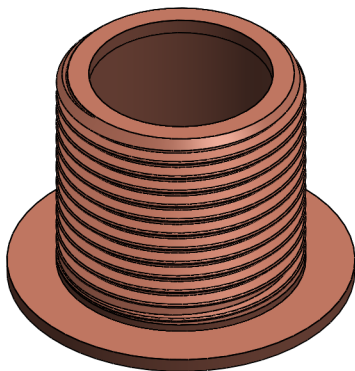
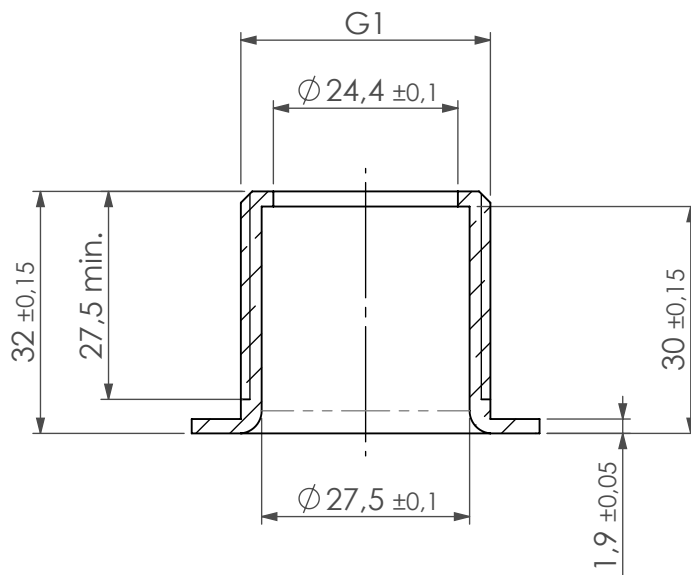
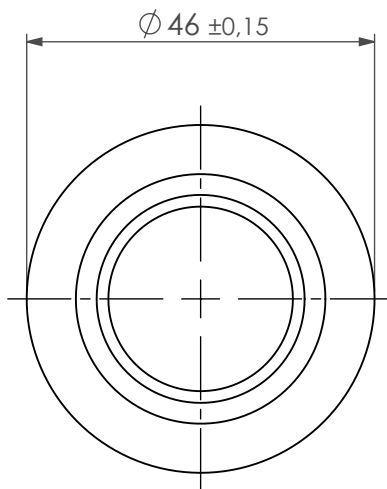

QUOTA MOLTO
IMPORTANTE:



Rugosità dove
 non espressa:



Codice cliente : /
 Indice di revisione : /

Concentricità ammessa tra
 parti grezze e lavorate: 0,5 mm

Grado di precisione medio UNI EN 22768-1

| | | | |
|-------------------|--------------|---------------------|--------------|
| da 0,5 fino a 6 | ± 0,1 | oltre 30 fino a 120 | ± 0,3 |
| oltre 6 fino a 30 | ± 0,2 | oltre 120 | ± 0,5 |

THEONILDE

BRASS NUTS AND NIPPLES
 www.theonilde.it e-mail: info@theonilde.it
 tel: +39 0365 599019 Fax: +39 0365 597528

Denominazione

CODOLO G1

Codice disegno

CU/D46.32/1

Materiale **CW024A**

Massa grezzo(g) **0.00**

Massa lavorato (g) **70.12**

Disegnato da

M. MARANGONI

Controllato da

M. MARANGONI

Data creazione **15/10/2014**

rev.

Trattamento

scala

Data ultima rev. **15/10/2014**

0

1:1

FORMATO A4